

Attn.: _____

HIROSE ELECTRIC CO., LTD.
2-6-3 Nakagawa Chuoh, Tsuzuki-ku, Yokohama, JAPAN

Product Change Notification

We are writing today to inform you that we will make some changes as shown in the subject for the reason described below.

We will announce them in advance.

1	Products affected	IX61-A-8P (CL:251-0001-2-00) IX61-B-8P (CL:251-0005-0-00)
2	Replacement product	There is no change in product code and product name.
3	Classification of change	Product specification change.
4	Changes	The DIP location dimension on the back of the product will be changed from 1.9 ± 0.2 to $1.9 +0.35/-0.2$. Please refer to the attachment 1 for detailed. These changes will not affect the performances of the product.
5	Reason for change	This is to improve productivity.
6	Schedule of change	The switch will be effective from shipments on October 1, 2023.
7	Regarding test data	There is no change in product performance.
8	Date of your acknowledgement	By September 27,2023

We kindly request that you inform Hirose business representative of your acknowledgement by the aforesaid date.

In the absence of a response by this date, please be advised that replacement product that described above will be delivered.

If you should have any questions, please feel free to contact a Hirose business representative.

Your understanding and cooperation are highly appreciated.

■ Dimensions of the changed part

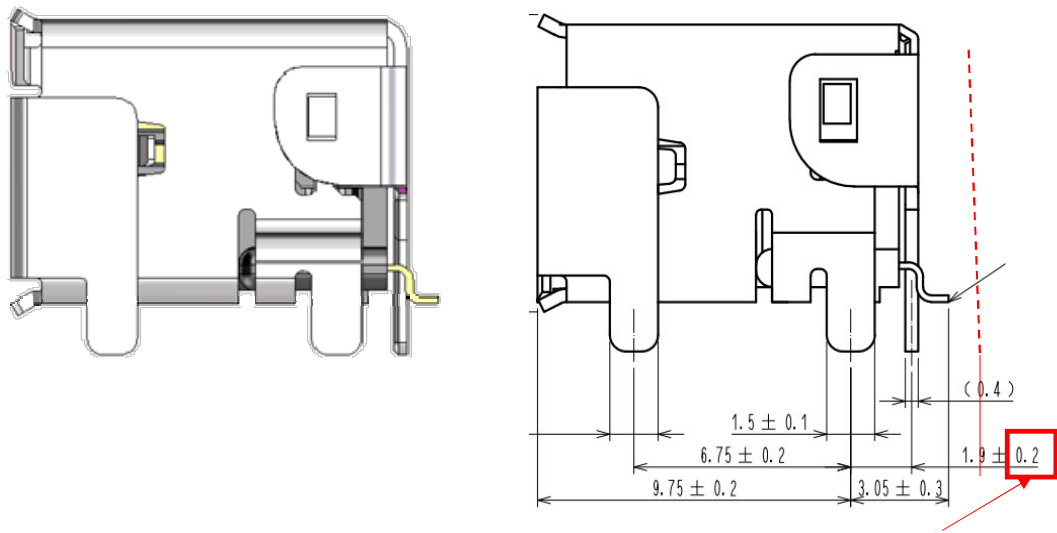
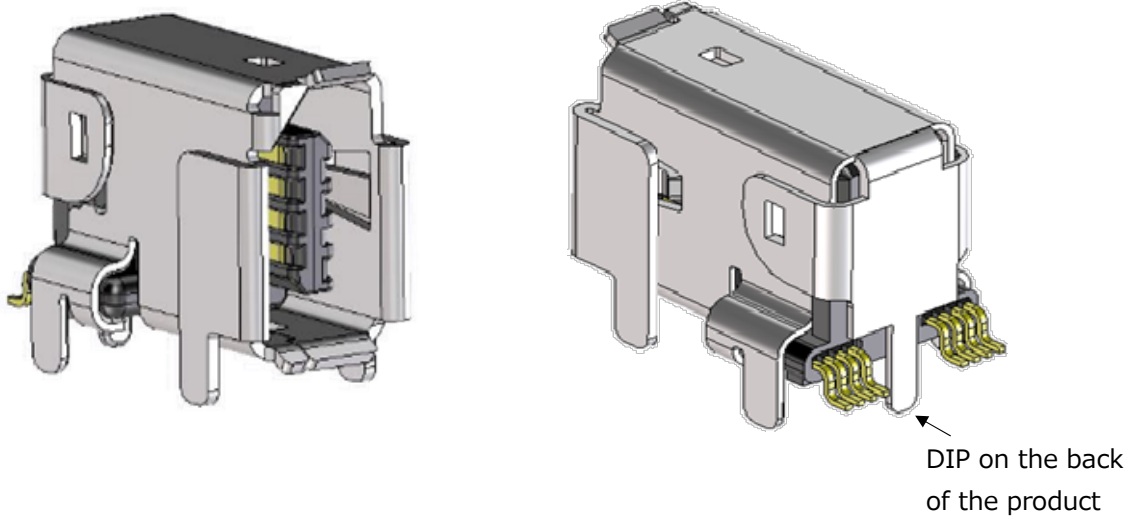

(Before) 1.9 ± 0.2
(After) $1.9 + 0.35 - 0.2$

After the change, all products will be inspected by location checkers in the assembly process to prevent defective products from escaping.

Interference with substrate

Clearance is available even under the worst-case combination of substrate-product conditions

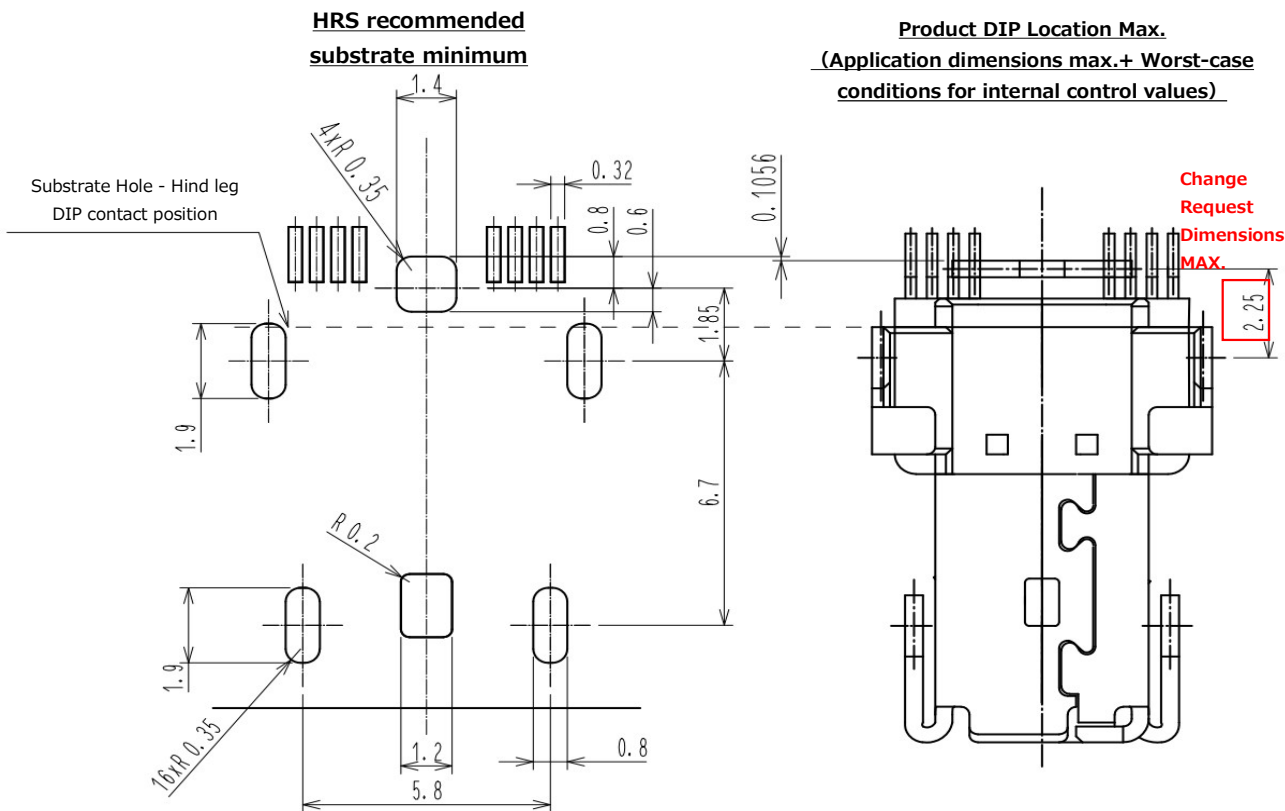

Worst case combination

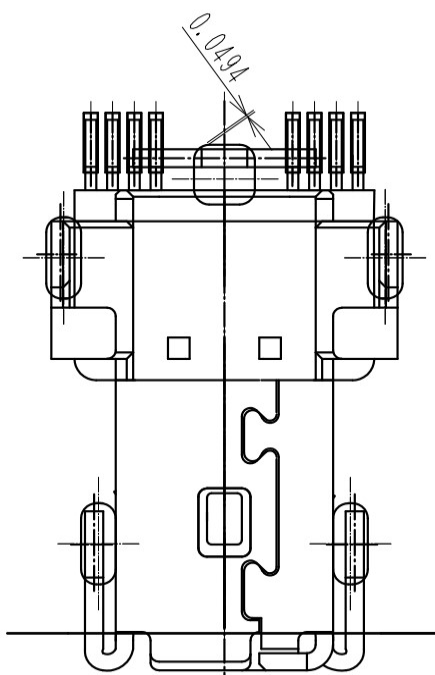

Even in worst case conditions with minimum board and maximum product DIP location, there is a clearance of approx. 0.05 at the shortest point between the DIP corner and the board hole corner.

There is no impact on implementation.

Acknowledgement

(Customer → Hirose Electric business representative)

Product Change Notification
Request for Your Acknowledgement

We acknowledge the changes and schedule of this notification.

Customer's name: _____

Acknowledgement stamp (or signature): _____

HIROSE ELECTRIC CO., LTD.

(Cut on this line)

Document Receipt

(Customer → Hirose Electric business representative)

Product Change Notification
Request for Your Acknowledgement

We received the document concerning the above.

Customer's name: _____

Acknowledgment stamp (or signature): _____

HIROSE ELECTRIC CO., LTD.