

REVISIONS			
REV.	DESCRIPTION	DATE	APPROVED
01	Original Document	11/13/15	BB

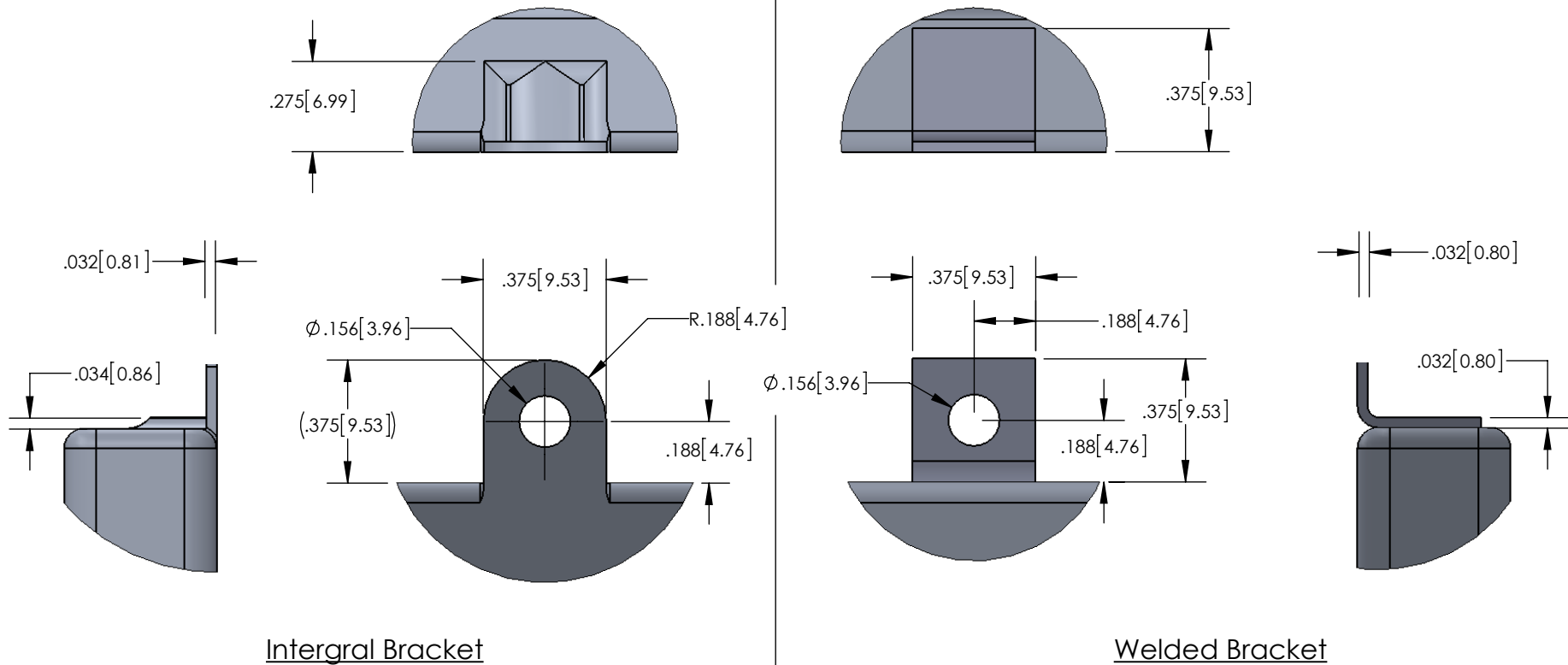

Integral Bracket

Welded Bracket

Tolerances Unless Specified:

FRACTIONAL $\pm 1/64$
 ANGULAR:
 MACH $\pm .5^\circ$ BEND $\pm .5^\circ$
 .XX $\pm .01$ " ; X $\pm .25$ mm
 .XXX $\pm .005$ " ; XX $\pm .13$ mm
 .XXXX $\pm .0005$ " ; XXX $\pm .013$ mm

MATERIAL

FINISH

DO NOT SCALE DRAWING

NAME	DATE
Drawn By: Blake B	11/13/15
Checked By: ...	

PROPRIETARY AND CONFIDENTIAL
 THE INFORMATION CONTAINED IN THIS DRAWING IS THE SOLE PROPERTY OF CORNELL DUBILIER.
 ANY REPRODUCTION IN PART OR AS A WHOLE WITHOUT THE WRITTEN PERMISSION OF CORNELL DUBILIER IS PROHIBITED.



TITLE:

Comparison

SIZE	DWG. NO.	REV
00853	Bracket Comparison	
WEIGHT: 0.02	SHEET 1 OF 1	

"CONTROLLED COPY" if viewed on CD server or if copy is stamped in RED, otherwise considered as an "UNCONTROLLED COPY"