

**1 Products affected**

Product hierarchy no. *				Part no.	SBU	Type / Description	Customer part no.
SBU	PG	PUG	Type				
80	084	002	0000006505	See list below	EMC	FMW-55	
80	084	002	0000006148	See list below	EMC	FSS-55	

\*SBU (2-digit) / PG (3-digit) / PUG (3-digit) / Type (10-digit)

List of part numbers affected				
5500.2045	5500.2046	5500.2047	5500.2051	5500.2052

**2 Type of change**

- Nickel plated steel case instead of aluminium case
- Different shape of external quick connect terminals
- Change of production site

**3 Detailed description of change**

- Change of product appearance due to new nickel plated steel case instead of aluminium case
- Different shape of plastic part for external quick connector terminals
- Moved position and turned protective earth terminal to a vertical position
- Change of factory code from SK to SC and origin from SK to CN on product and packaging labels

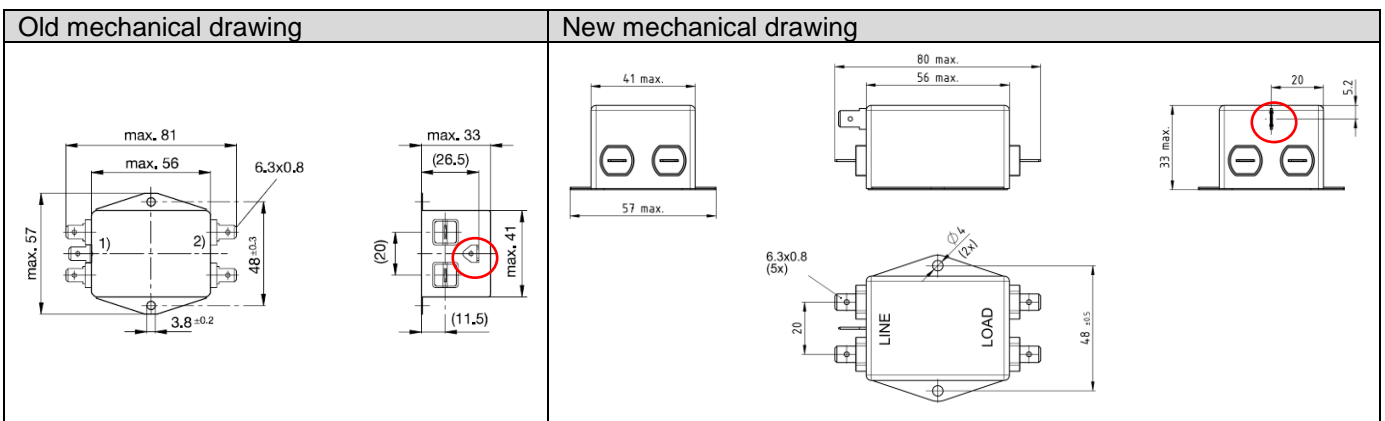

Product Change Notification						PCN FMW-55 FSS-55 case 10 redesign	
owner	creation date	release date	released by	change order no	rev	page	D10-041-503
segatro	04.12.2019	10.12.2019	canoniar	2018652	A	1 of 2	

Old product label (example)	New product label (example)
<p>SCHURTER 5500.2052 FSS2-55-2/0.5 125/250VAC 50/60Hz 2A@40°C 25/100/21</p> <p>2x10mH 0.4mH LINE PE N N' LOAD 0.1µF(X2) 2x1.5nF(Y2) 2x1nF(Y2) 0.47µF(X2)</p> <p>10 IEC 60639 C ALUS SK 1945</p>	<p>SCHURTER 5500.2052 FSS2-55-2/0.5 125/250VAC 50/60Hz 2A@40°C 25/100/21</p> <p>2x10mH 0.4mH LINE PE N N' LOAD 0.1µF(X2) 2x1.5nF(Y2) 2x1nF(Y2) 0.47µF(X2)</p> <p>10 IEC 60639 C ALUS SC 1945</p>
Old packaging label (example)	New packaging label (example)
<p>SCHURTER 5500.2052 Part No. 5500.2052 Qty. 10 FSS 2A 250V Cr Less Ref FSS2-55-2/0.5 Lot No. 123456789 Date Code 1945 SK Co.Cr. SK</p>	<p>SCHURTER 5500.2052 Part No. 5500.2052 Qty. 10 FSS 2A 250V Cr Less Ref FSS2-55-2/0.5 Lot No. 123456789 Date Code 1945 SC Co.Cr. CN</p>

#### 4 Reason of change

- Improved filter performance due to completed closed steel case
- Reorganization of production process
- Production site transfer from Slovakia to China

#### 5 Release date

The change will be rolled-out starting wk10/2020 (Date code 2010 or higher on label) and lasts approx. 6 months depending on the variant.

#### 6 Impact of change and recommended action

Form	Yes	New material and different quick connect terminals
Fit	Yes	Earth terminal position
Function	No	No change in function
Manufacturing	Yes	Change of production site
Label	Yes	Change on label
Packaging	No	Change in packaging

#### 7 Reference Documents / Attachments

Kind of document	Remarks
<a href="#">FMW-55</a>	
<a href="#">FSS</a>	

Product Change Notification					PCN FMW-55 FSS-55 case 10 redesign		
owner	creation date	release date	released by	change order no	rev	page	D10-041-503
segatro	04.12.2019	10.12.2019	canoniar	2018652	A	2 of 2	